

## FAN COIL UNITS





Tahviah Azar Nasim Company pioneers in air conditioning system productions and industrial processes in Iran. Decorative Fan Coil Units with unique design and structure is one of the well known products of our company.



#### General Description:

- Azar Nasim fan coil units are stepped decorative type in different capacities from 340 m<sup>3</sup>/hr to 1700 m<sup>3</sup>/hr and manufacture in three kinds:

1. Ceiling fan coil unit without cabin
  2. Floor mounted fan coil units decorative (with cabin)
  3. Ceiling mounted fan coil units decorative (with cabin)
- A. Outlet air is adjustable in four directions.
  - B. Main structure of the units is made of Aluminum profiles.
3. Sides and air outlets are made of ABS.
- A. Front panel of the unit is made of mild steel sheets and coated with electrostatic powder paint.
  - B. All internal sheets and condensate tray are hot dip galvanized coated with aero flex insulator.

#### - Coils:

1. Three rows coils (8 tubes in each row) from copper tubes with diameters of 10mm and aluminum fins with spacing of 4.72 fin/cm is standard part of all Azar Nasim fan coil units. All the coils are degreased, washed and tested up to 14 bar.

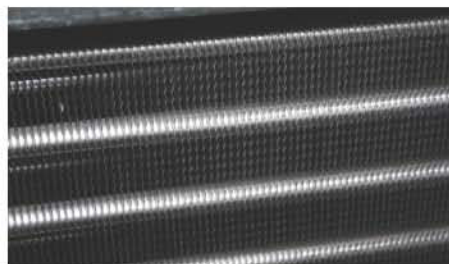

#### Electro motors:

- 1- Fan coil units electromotor are single phase 4speeds, with heat relay to protect the electro motor winding against over loading.

#### - Fans:

ABS or Steel centrifugal fans which statically and dynamically balanced with low noise level are used.

#### - Filter:

Air filter is mounted at air inlet with ABS frame and easily cleanable.

#### - Key Board:

Electric key board with OFF chassis and 4 speed touch keys (Night mode, 1-2 and 3) is mounted on fan coil units. Remote control can be provided on client's request.

#### - Intelligent Systems:

This system installed on the fan coil units to protect energy wasting. In case of failure of chiller, boiler, or circulation pump or air trap in the coil, intelligent system automatically off the fan coil until the problem is solved.

**- Decorative Fan Coil Units**

- Floor mounted (TDFF)
- Wall mounted (TDFW)
- Ceiling mounted (TDFC)

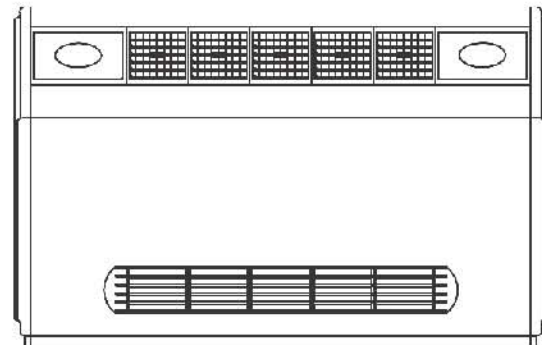

**- Ceiling Mounted Compact Concealed Fan Coil**

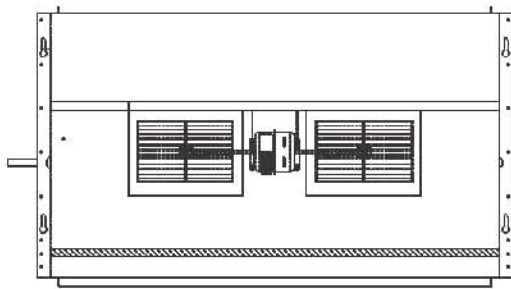

**Model L**  
**TCFL**

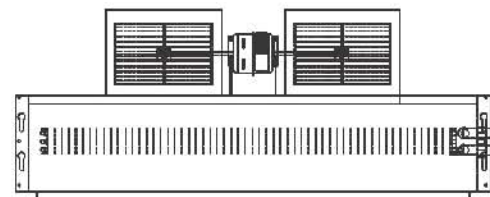

**Model H**  
**TCFH**

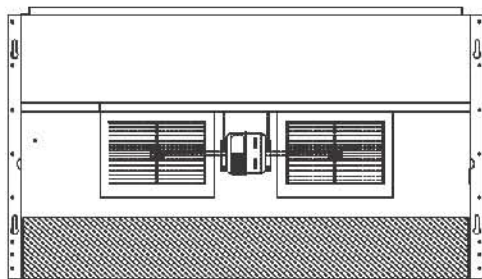

**Model U**  
**TCFU**



## Decorative Fan Coil Units

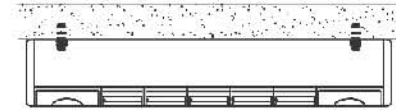
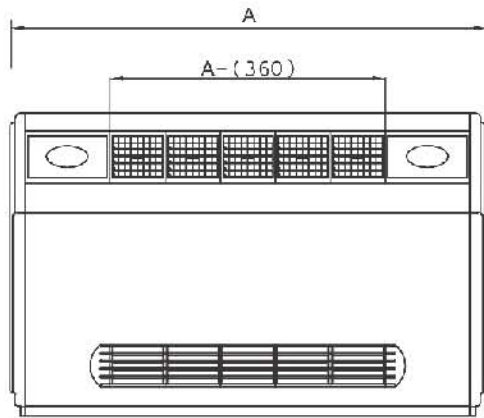

Ceiling mounted

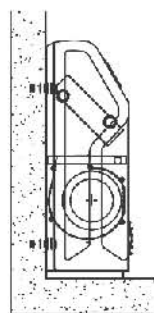
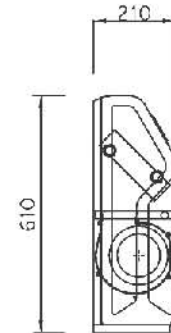
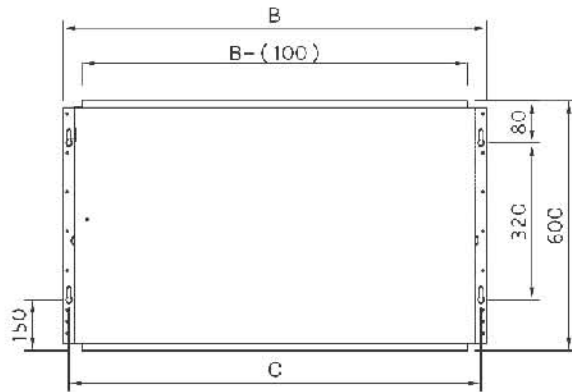

Floor mounted

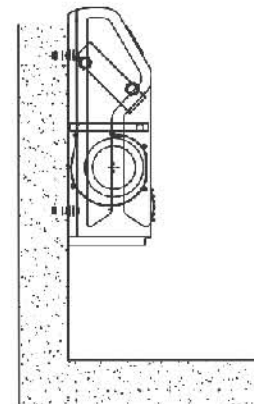

Wall mounted

**Table1** Exposed Decorative Fan Coil Dimensions

MODEL	350	510	680	1020	1400	1700
A (mm)	864	990	1116	1240	1620	1995
B (mm)	562	687	812	937	1312	1687
C (mm)	540	665	790	920	1290	1667

### Ceiling Mounted Concealed Fan Coil Units Angle Air flow

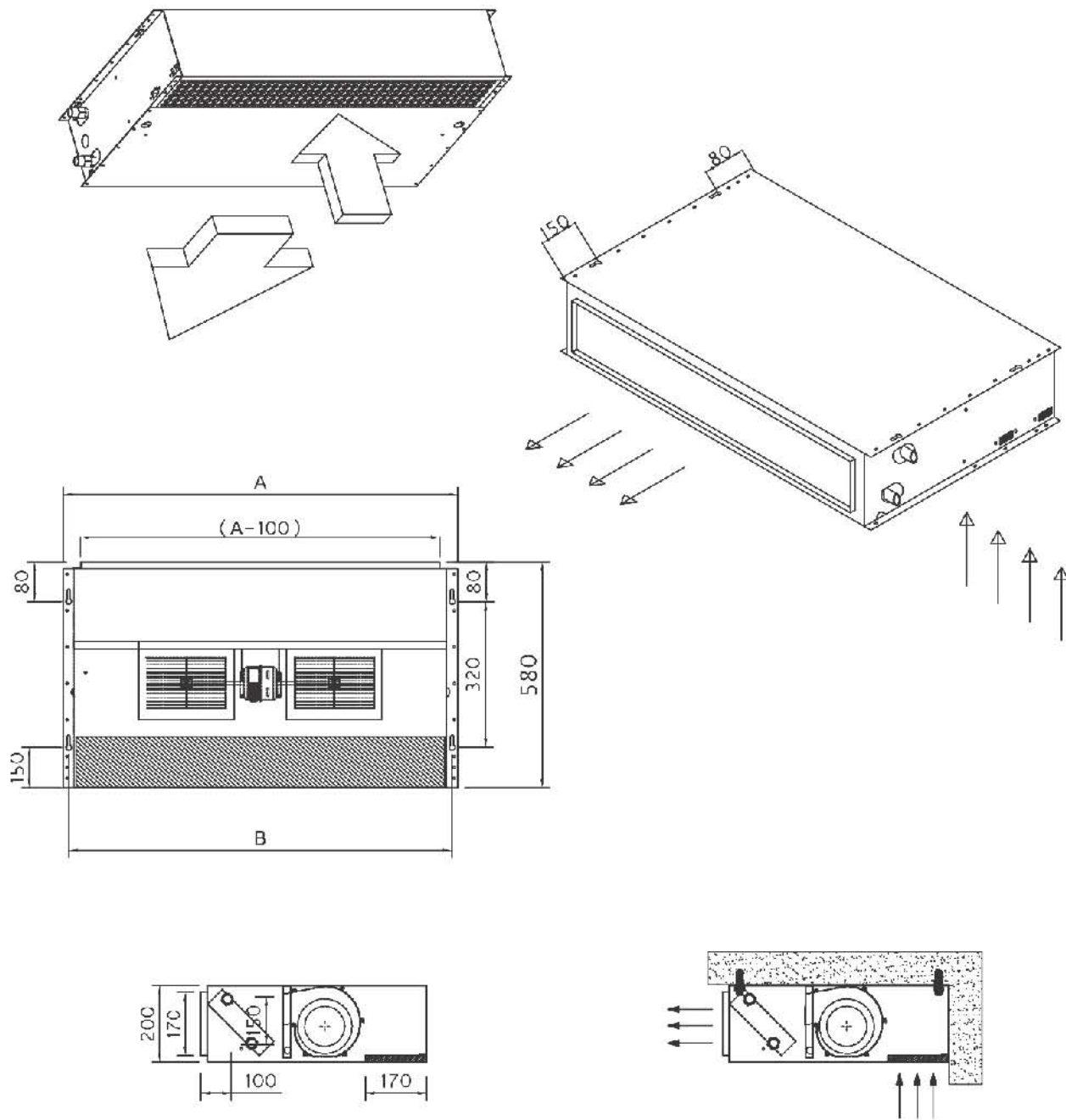
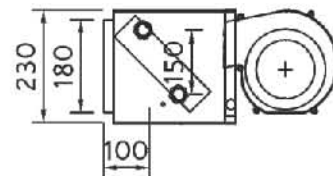
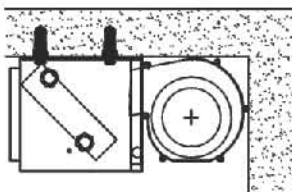
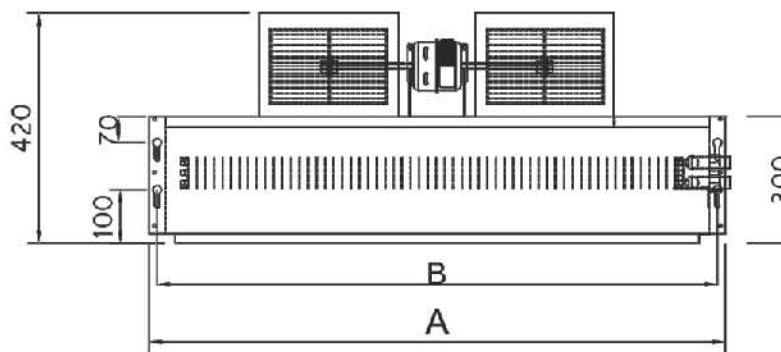
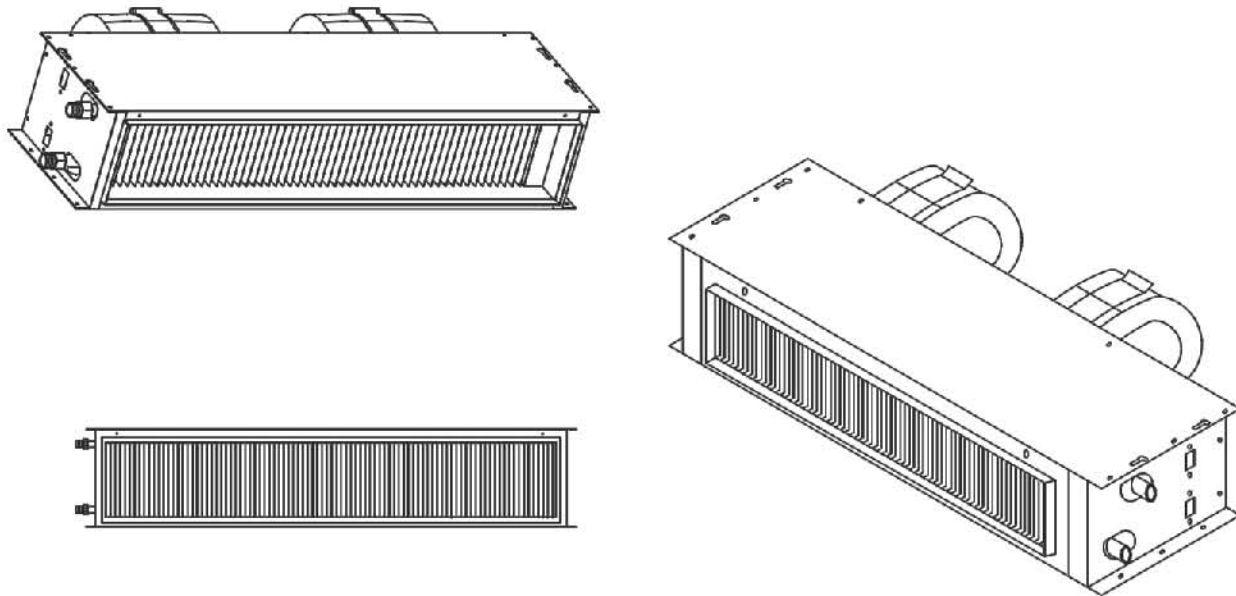

Table 2		Ceiling Mounted Concealed Fan Coil Dimensions				
MODEL	350	510	680	1020	1400	1700
A (mm)	562	687	812	937	1312	1687
B (mm)	540	665	790	920	1290	1667





### Ceiling Mounted Concealed Fan Coil Units Short length



**Table 4** Ceiling Mounted Concealed Fan Coil Dimensions

MODEL	350	510	680	1020	1400	1700
A (mm)	610	720	940	1050	1380	1600
B (mm)	562	687	812	937	1312	1687



Table 5 Physical Specifications						
Description	Unit Size					
	350	510	680	1020	1400	1700
Nominal Air Flow Rate (m <sup>3</sup> /hr)	350	510	680	1020	1400	1700
*Unit Weight(Kg)	21	24	27	30	45	54
Number of Motors	1	1	1	1	2	2
Nominal Power (W)	25	25	45	45	2×45	2×45
Total Rated Amps	0.4	0.4	0.65	0.65	1.05	1.3
Coil Face Area (m <sup>2</sup> )	0.09	0.13	0.15	0.178	0.233	0.295
Tube Size	10mm O.D.					
No of Rows	3					
No of Fins/cm	4.72					

\*Unit weights giving are for exposed models. For concealed reduce values by approximately 35%

Table 6 Nominal Performance Data						
MODEL	Air Flow (m <sup>3</sup> /hr)	Cooling			Heating	
		Total Cap. (KW)	Sensible Cap. (KW)	Water Flow (m <sup>3</sup> /hr)	Capacity (KW)	Water Flow (m <sup>3</sup> /hr)
350	350	2.7	1.8	0.45	6.4	0.57
510	510	3.6	2.6	0.57	9	0.8
680	680	4.5	3.6	0.8	11.4	0.91
1020	1020	5.8	4.3	0.9	14.1	1.14
1400	1400	7.2	5.4	1.14	18.4	1.48
1700	1700	9	6.8	1.48	22	1.7

**Notes:**

- 1- Capacities are based on high fan speed.
- 2- Cooling capacities are based on entering water at 7 °C and entering air at 27 °C D.B., 19.5 °C W.B.
- 3- Heating capacities are based on entering air at 21 °C D.B. entering and leaving water at 81 °C and 71 °C respectively.



**Table 7 Chilled Water Ratings**

Model	Entering water temperature (°C)	Flow m <sup>3</sup> /hr	Pressure Drop(KPa <sub>a</sub> )	17 WB. Sensible (KW.)	Entering air temperature (°C)				
					24 DB. Total (KW)	18.5 WB. Sensible (KW)	25DB Total (KW)	19.5WB. Sensible (KW)	26.5DB. Total (KW)
350	5.5	0.34	6.6	1.76	2.23	1.82	2.48	1.9	2.75
		0.45	11	1.9	2.4	1.96	2.71	2.05	3.05
		0.57	16	2	2.6	2.11	2.87	2.2	3.22
	6.5	0.34	6.6	1.6	2	1.67	2.26	1.76	2.55
		0.45	11	1.76	2.23	1.82	2.48	1.9	2.75
		0.57	16	1.9	2.4	1.96	2.67	2.05	2.93
	7.5	0.34	6.6	1.32	1.8	1.47	2.05	1.61	2.35
		0.45	11	1.5	2	1.61	2.2	1.76	2.52
		0.57	16	1.6	2.14	1.76	2.43	1.9	2.75
510	5.5	0.45	13	2.34	2.9	2.46	3.19	2.64	3.51
		0.57	20	2.5	3.16	2.55	3.49	2.78	3.84
		0.68	27	2.64	3.3	2.76	3.62	2.93	4
	6.5	0.45	13	2.2	2.6	2.35	2.9	2.5	3.22
		0.57	20	2.34	2.81	2.5	3.14	2.64	3.52
		0.68	27	2.5	3	2.64	3.33	2.78	3.75
	7.5	0.45	13	1.9	2.31	2.11	2.61	2.35	2.93
		0.57	20	2	2.52	2.26	2.84	2.49	3.22
		0.68	27	2.2	2.64	2.4	3	2.64	3.4
680	5.5	0.57	20	3	3.8	3.22	4.16	3.37	4.63
		0.68	27	3.22	4	3.37	4.4	3.51	4.87
		0.8	35	3.4	4.16	3.52	4.6	3.66	5.1
	6.5	0.57	20	2.9	3.4	3.14	3.81	3.37	4.22
		0.68	27	3	3.58	3.28	4.01	3.52	4.51
		0.8	35	3.22	3.75	3.43	4.21	3.66	4.69
	7.5	0.57	20	2.64	3.05	5.77	3.46	3.22	3.93
		0.68	27	2.8	3.2	3.05	3.63	3.37	4.1
		0.8	35	2.9	3.34	3.19	3.81	3.52	4.34
1020	5.5	0.8	13	3.8	5	4.16	5.54	4.54	6.15
		0.91	16	4	5.25	4.31	5.8	4.69	6.42
		1	19	4.1	5.45	4.45	6.04	4.84	6.68
	6.5	0.8	13	3.66	4.5	3.96	5.07	4.25	5.69
		0.91	16	3.8	4.75	4.1	5.33	4.4	5.98
		1	19	4	4.93	4.22	5.52	4.54	6.15
	7.5	0.8	13	3.4	4	3.72	4.59	4.1	5.22
		0.91	16	3.5	4.22	3.87	4.84	4.25	5.51
		1	19	3.7	4.4	4	5.04	4.4	5.74
1400	5.5	1	23	5.13	6.33	5.57	7.04	6	7.74
		1.17	28	5.28	6.54	5.72	7.21	6.15	7.97
		1.25	33	5.4	6.7	5.86	7.41	6.3	8.21
	6.5	1	23	5	5.8	5.13	6.45	5.27	7.15
		1.17	28	5.13	6	5.27	6.64	5.42	7.35
		1.25	33	5.28	6.13	5.39	6.83	5.57	7.62
	7.5	1	23	4.4	5.1	4.75	5.86	5.13	6.62
		1.17	28	4.5	5.4	4.9	6.1	5.27	6.86
		1.25	33	4.7	5.51	5.04	6.24	5.42	7.06
1700	5.5	1.36	21	6.15	8	6.74	8.82	7.33	9.73
		1.48	24	6.3	8.18	6.89	9.03	7.47	9.96
		1.6	27	6.6	8.32	7.1	9.17	7.62	10.14
	6.5	1.36	21	6	7.33	6.36	8.21	6.74	9.08
		1.48	24	6.15	7.45	6.51	8.35	6.89	9.32
		1.6	27	6.5	7.56	6.71	8.44	7.03	9.44
	7.5	1.36	21	5.4	6.56	5.98	7.44	6.59	8.44
		1.7	24	5.57	6.7	6.12	7.58	6.74	8.5
		1.7	27	5.7	6.83	6.27	7.77	6.89	8.79

**Notes:**

1- Capacities are based on high fan speed.

2- For unit capacities at med. or low speed , multiply table values by the given correction factor.

Motor Speed	Correction Factor
Medium	0.90
Low	0.80



**Table 8 Hot Water Ratings**

Model	Entering water temperature (°C)	m <sup>3</sup> /hr	Pressure Drop (KPa <sub>g</sub> )	Entering air temperature (°C)		
				20 DB. Total Heat (KW)	21 DB. Total Heat (KW)	22 DB. Total Heat (KW)
350	60	0.56	11	4.1	3.72	3.37
		0.68	16	4.25	3.87	3.52
		0.45	22	4.4	4.01	3.66
	71	0.56	11	5.27	5.05	4.84
		0.68	16	5.42	5.19	5
		0.68	22	5.57	5.33	5.13
	82	0.45	11	6.45	6.21	6
		5.7	16	6.6	6.36	6.15
		0.68	22	6.74	6.45	6.3
510	60	0.68	27	5.71	5.48	5.27
		0.8	34	5.86	5.63	5.42
		0.91	44	6	5.77	5.57
	71	0.68	27	7.47	7.18	6.89
		0.8	34	7.62	7.33	7.03
		0.91	44	7.77	7.47	7.18
	82	0.68	27	9.23	8.85	8.5
		0.8	34	9.39	9	8.65
		0.91	44	9.53	9.14	8.8
680	60	0.8	34	7.18	6.95	6.74
		0.91	44	7.33	7.09	6.89
		1.02	54	7.47	7.24	7.03
	71	0.8	34	9.53	9.23	8.96
		0.91	44	9.67	9.39	9.09
		1.02	54	9.82	9.53	9.23
	82	0.8	34	11.43	11.2	11
		0.91	44	11.58	11.34	11.14
		1.02	54	11.72	11.49	11.28
1020	60	1.02	19	9.23	8.85	8.45
		1.17	22	9.39	9	8.65
		1.25	27	14.5	14.2	14.6
	71	1.02	19	11.72	11.43	11.14
		1.17	22	11.87	11.58	11.28
		1.25	27	12.02	11.72	11.43
	82	1.02	19	14.21	13.98	13.77
		1.17	22	14.36	14.13	13.92
		1.25	27	14.51	14.27	14.07
1400	60	1.36	38	12.02	11.63	11.28
		1.48	43	12.16	11.78	11.43
		1.59	48	12.31	11.93	11.58
	71	1.36	38	15.24	14.95	14.65
		1.48	43	15.39	15.1	14.8
		1.59	48	15.53	15.24	14.95
	82	1.36	38	18.61	18.23	17.88
		1.48	43	18.76	18.38	18
		1.59	48	18.9	18.52	18.17
1700	60	1.7	30	14.51	14.13	13.77
		1.82	34	14.65	14.27	13.92
		1.93	38	14.8	14.42	14.07
	71	1.7	30	18.32	17.94	17.58
		1.82	34	18.46	18.1	17.73
		1.93	38	18.61	18.23	17.88
	82	1.7	30	22.27	22	21.69
		1.82	34	22.42	22.14	21.83
		1.93	38	22.57	22.27	22

**Notes:**

1- Capacities are based on high fan speed.

2- For unit capacities at med. or low speed , multiply table values by the given correction factor.

Motor Speed	Correction Factor
Medium	0.90
Low	0.80